



What's New in RhinoCAM 2021

Dec 31, 2020

This document describes new features and enhancements introduced in the RhinoCAM 2021 product.

NOTE: This information is provided in good faith but MecSoft reserves the right to modify or omit any of the items described in this document when RhinoCAM 2021 is released.

What's New in RhinoCAM 2021

CONTENTS

RhinoCAM 2021.....	4
Common Enhancements	4
Licensing Enhancements	6
RhinoCAM Software Development Kit (SDK) Enhancements.....	6
What's new in the MILL module.....	7
Usability Enhancements.....	7
Fixtures Enhancements	8
2-Axis Enhancements	9
3-Axis Enhancements	11
4 Axis Toolpath Enhancements	13
5 Axis Toolpath Enhancements	14
Hole Making Enhancements.....	15
Toolpath Editor Enhancements.....	16
Feeds/Speeds Enhancements	16
Simulation Enhancements.....	17
Machine Tool Simulation Enhancements.....	17
Knowledge Base Enhancements	17

What's New in RhinoCAM 2021

Post Processor Enhancements	18
What's new in the TURN module	19
What's new in the G-code Editor Module	20
What's new in the Profile-NEST module	21
What's new in the NEST module	21
What's new in the ART module	21
What's new in the MESH module	21
Bugs Fixed	22

What's New in RhinoCAM 2021

This document describes the new functionality that is being introduced with the release of the RhinoCAM 2021 product. This document is organized by listing and describing each of the enhancements incorporated into each of the constituent modules of RhinoCAM.

RHINOCAM 2021

RhinoCAM 2021 is a plug-in that runs inside the Rhinoceros 6.0 and 7.0 NURBS modeler from McNeel & Associates and hosts the following modules:

1. MILL
2. TURN
3. NEST
4. ART
5. GCODE EDITOR
6. PROFILE-NEST

Each of these modules can be licensed and invoked separately of the other modules. This section describes the various enhancements and improvement to each of the modules.

COMMON ENHANCEMENTS

This section describes the common enhancements and changes to RhinoCAM 2021.

1. The new SubD surface type introduced in Rhino 7.0 can now be utilized in RhinoCAM 2021 for Rhino 7.0 product. Rhino SubD objects are high precision spline based surfaces and thus introduce a level of accuracy to the process of creating complex freeform shapes. Whilst traditional SubD 'push-pull' editing of edges, faces and vertices is enabled, Rhino's surface commands such as Loft, Revolve, Sweep 1 & 2 and Extrude all now produce direct SubD output. RhinoCAM can read and use SubD surfaces directly in toolpath creation. A few examples are shown below.

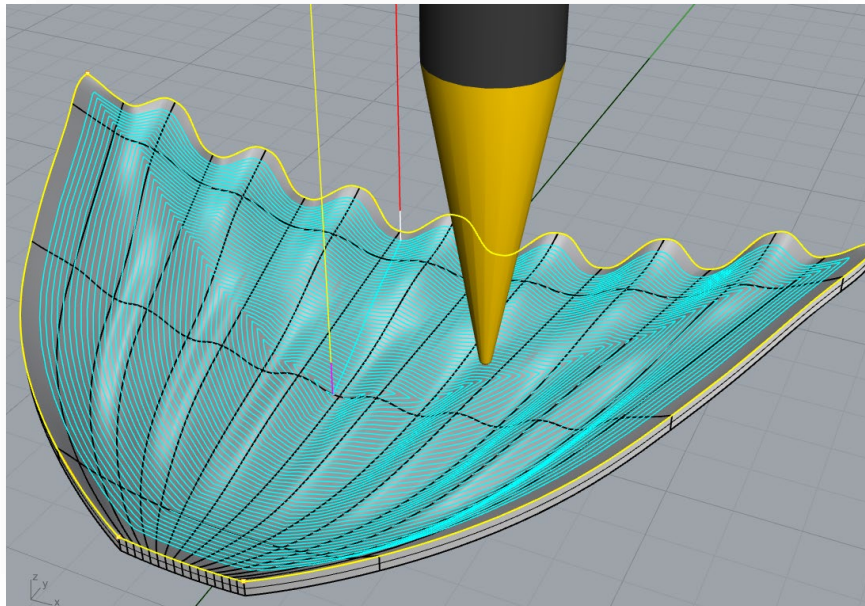

3 Axis toolpath on a SubD surface model

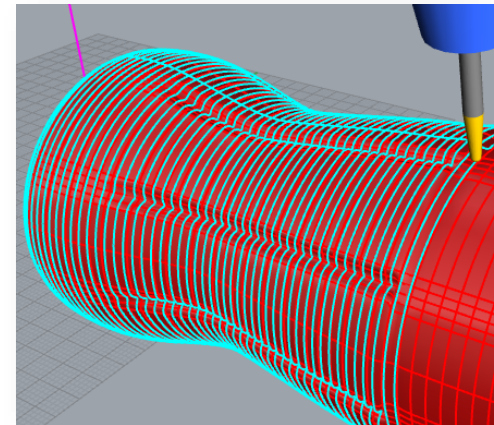

4 Axis toolpath on a SubD surface model

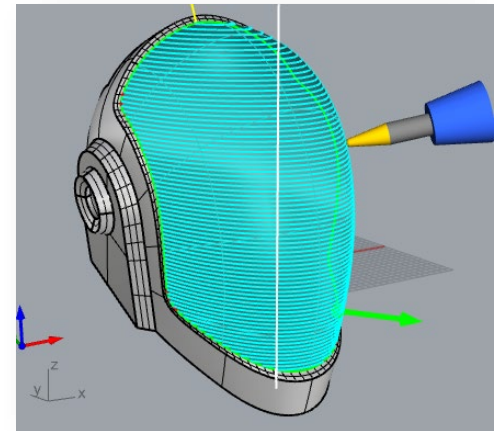

5 Axis continuous toolpath on a SubD surface model

2. Handling of blocks has been enhanced and made more robust.
3. A new version of the windowing system for RhinoCAM has been integrated into the 2021 product

What's New in RhinoCAM 2021

4. New simulation libraries from Machineworks has been incorporated into all the machining modules. These libraries have improved multi-threaded performance significantly as well as fixed many reported issues.

LICENSING ENHANCEMENTS

The following enhancements have been implemented in the licensing system for RhinoCAM.

1. Ability to automatically fix node-locked licenses that are locked out due to internet issues has been introduced
2. Support for Centos 7.0 has been added to the MecSoft license server product

RHINOCAM SOFTWARE DEVELOPMENT KIT (SDK) ENHANCEMENTS

The following enhancements have been added to the RhinoCAM SDK

1. All Machining Operations that present in the Express configuration can now be created/edited using the API
2. Ability to create Stock models using the API has been added
3. The API now allows the ability to modify tooling parameters in existing tools
4. The API has been enhanced to add and modify additional Machining Parameters
5. New API example programs have been added to the RhinoCAM SDK

What's New in RhinoCAM 2021

WHAT'S NEW IN THE MILL MODULE

This section describes the enhancements and changes to the MILL module.

USABILITY ENHANCEMENTS

1. A clone command for Machining Operations was implemented.

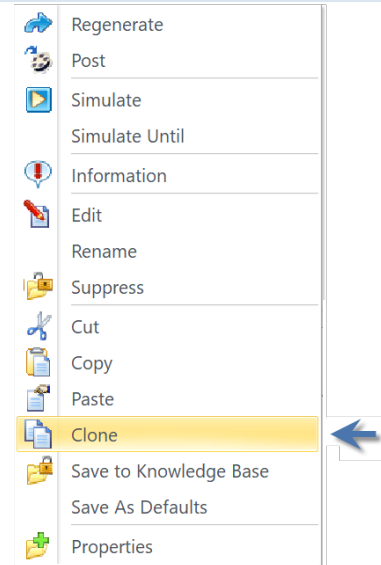

2. A new pop-Up message display window was implemented. These windows display informational messages and do not require user interaction.

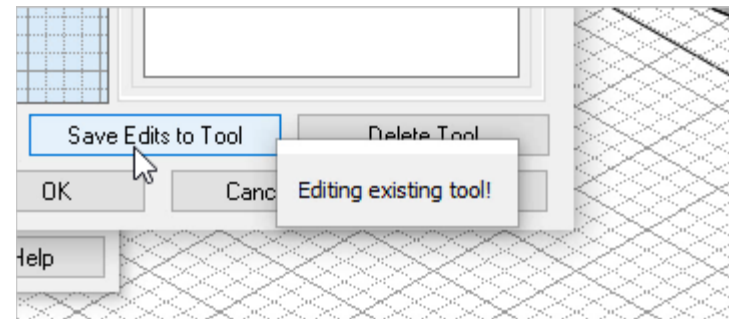

What's New in RhinoCAM 2021

- The spindle speed associated with a Machining Operation is now displayed in the operation information dialog

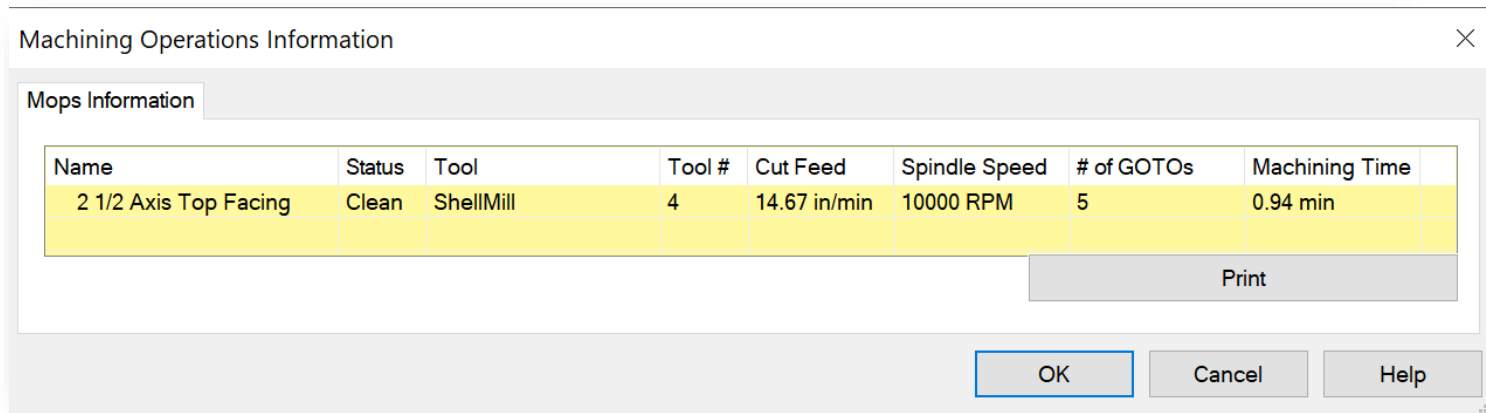

- Dialog pictures have been made more machining specific throughout the system.

FIXTURES ENHANCEMENTS

- Fixtures are now associated more tightly with machining operations, such that when the geometry of the fixtures are updated, the associated operations are marked as needing regeneration.

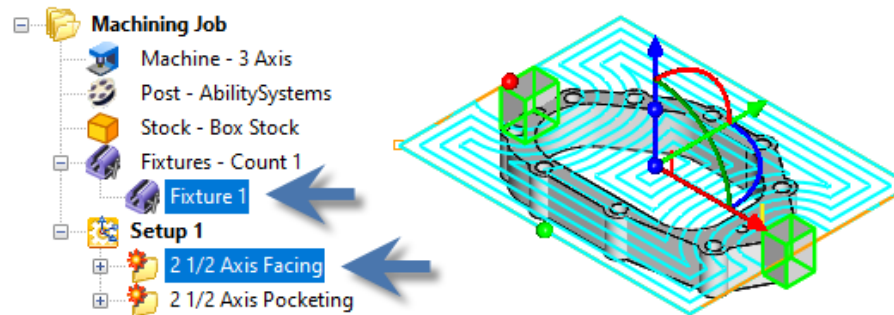

2-AXIS ENHANCEMENTS

1. A new machining method called Face Top Machining has been implemented. When using this method, the system computes the optimum angle to machine the top of the stock model using the minimum number of cuts.

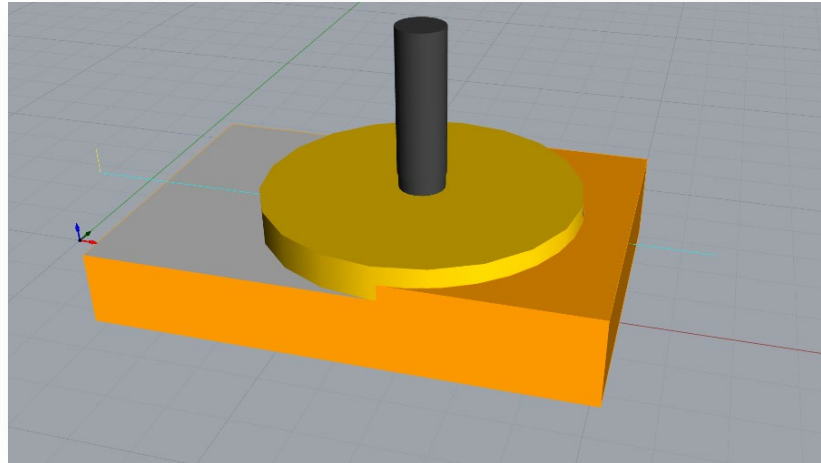

2. Bridges can now be created in the Engraving operation. Both rectangular and triangular bridges can be created.

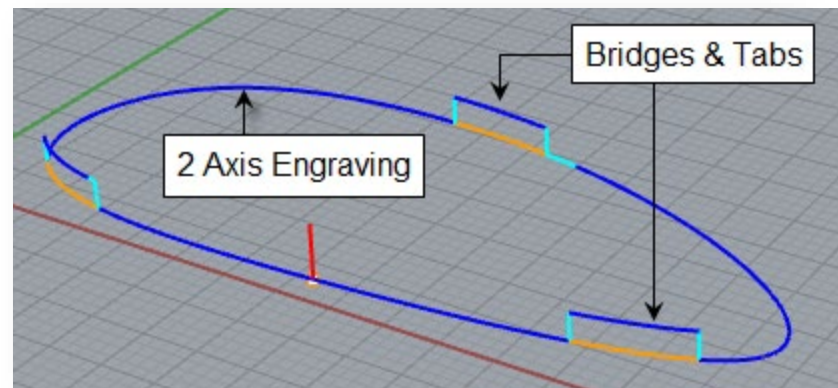

What's New in RhinoCAM 2021

3. User selected Start Points for 2 Axis Profiling operations were implemented

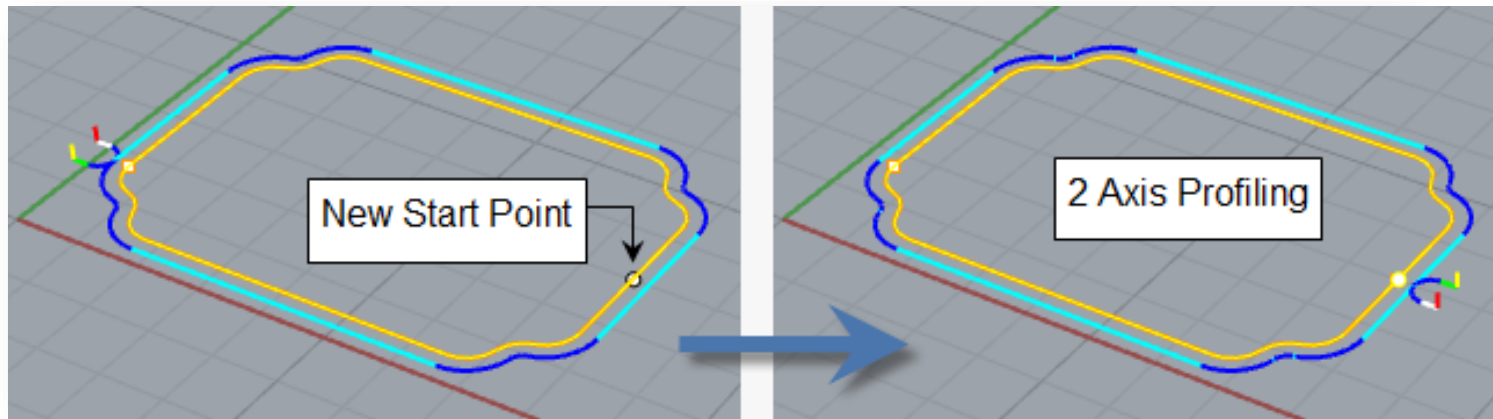

4. A setting to automatically round external corners by tool radius in Profiling and Pocketing machining methods has been implemented. This can be useful when creating inlays.

3-AXIS ENHANCEMENTS

1. A new machining method called Adaptive Roughing machining method has been implemented. Adaptive Roughing allows the cutter to move in such a way as to remove material at a constant engagement. This method has the ability to save tool and machine life due to smooth cutting being performed. (This method is a separately licensed method and needs to be purchased separately)

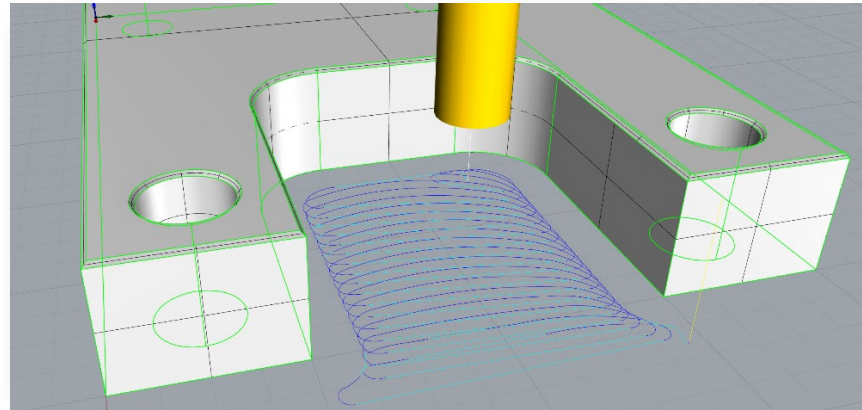

2. User selected Start Points in 3 Axis Horizontal Finishing was implemented

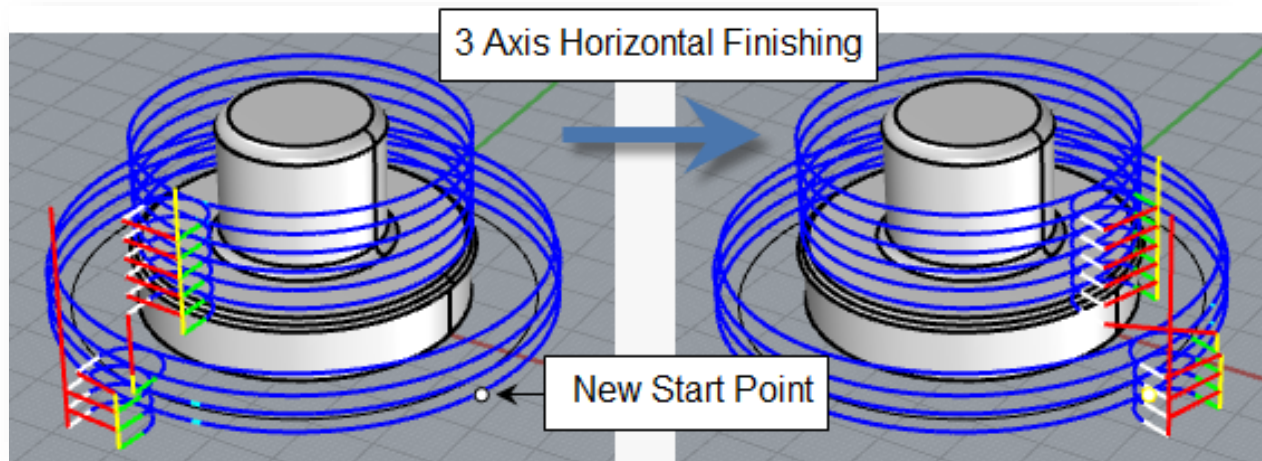

3. Cut transfers were enhanced to enable the user to add a tangential lift as well as to reduce the federate for High Speed machining toolpaths

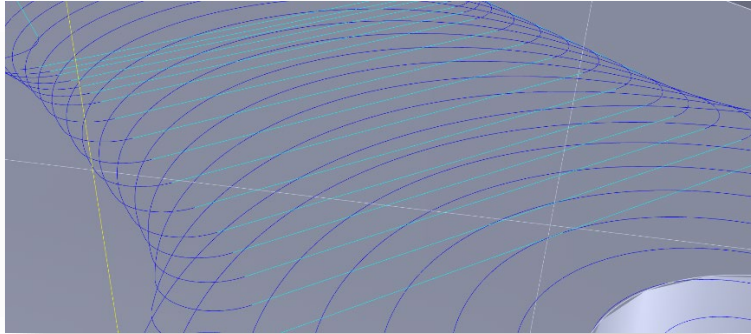

High Speed toolpath with transfer motions at same height as toolpath

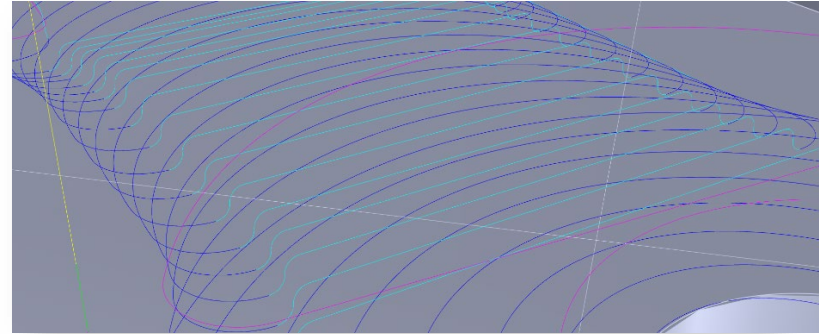

Transfer motions with a tangential lift added

4. The Clear Flats option in horizontal Finishing was enhanced to remove unwanted toolpaths

4 AXIS TOOLPATH ENHANCEMENTS

1. Multiple roughing cut levels in 4 Axis Projection Pocketing was introduced

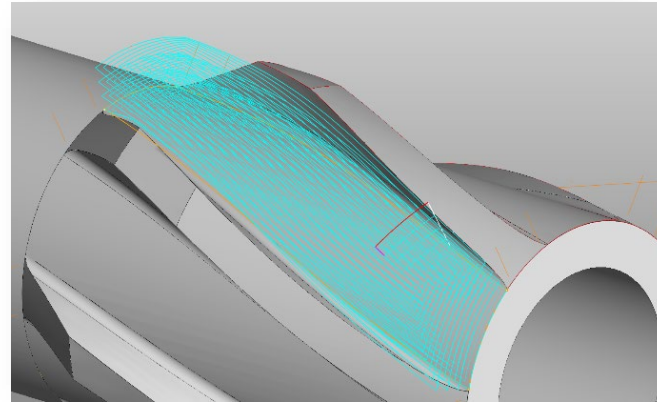

2. Helical pattern in Drive Surface Machining was introduced

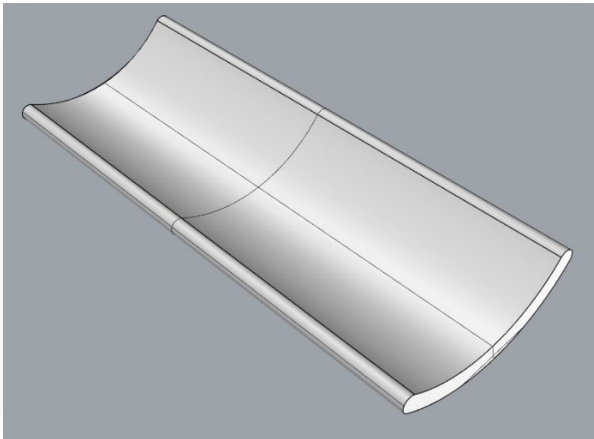

Drive Surfaces used in 4 Axis Drive Surface machining

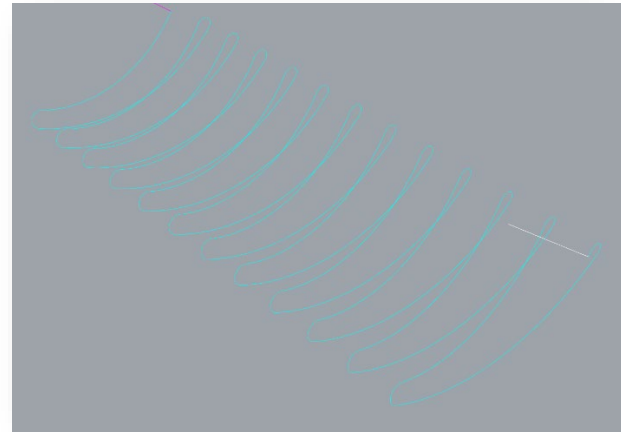

New helical toolpath created to machine the surfaces

What's New in RhinoCAM 2021

3. An option to choose between Zig and Zig Zag in 4 Axis Engraving, when performing multiple passes has been implemented. Additionally, the Cut Levels dialog has been made similar to the 2 ½ Axis Cut Level dialog.

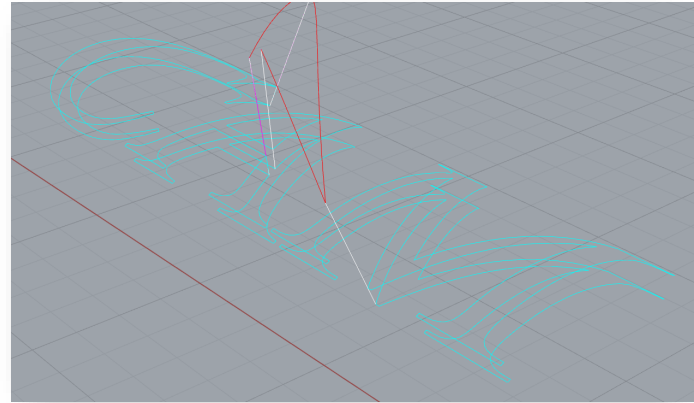

5 AXIS TOOLPATH ENHANCEMENTS

1. Additional controls for tool axis control has been implemented in all 5 Axis Machining methods. This allows better control of the tool axis in tight spaces for simultaneous 5 Axis machining.

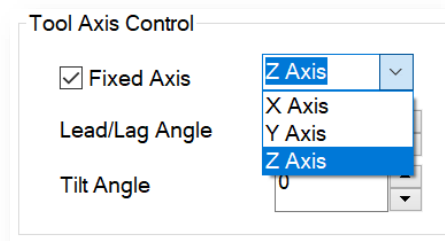

2. New Moduleworks toolpath generation libraries for 5 axis machining have been integrated with the product.

HOLE MAKING ENHANCEMENTS

1. Holes selection behavior was changed in the Hole Pocketing and Hole Profiling operations

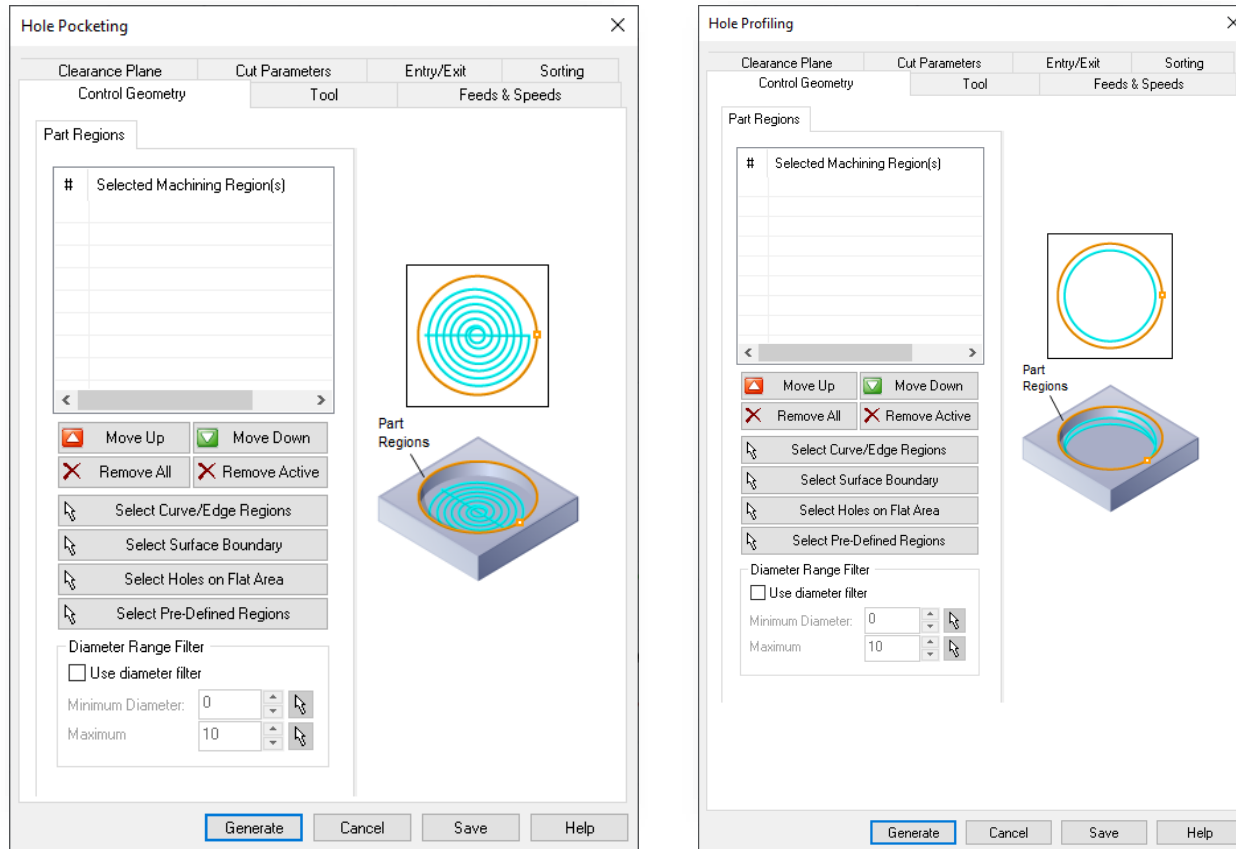

Dialog for selection of holes with filters in both hole pocketing and hole profiling

What's New in RhinoCAM 2021

SIMULATION ENHANCEMENTS

1. The graphics display was streamlined when simulation switches from one operation to the next in the operation tree
2. Follow, Trace and Segment toolpath display modes have been implemented

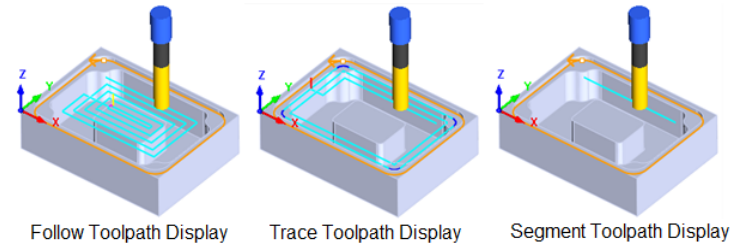

MACHINE TOOL SIMULATION ENHANCEMENTS

1. Additional machine tool models have been added as part of the installed machine tool simulation library.

KNOWLEDGE BASE ENHANCEMENTS

1. Ability to use the saved stock or to create a stock model based on saved rules has been implemented
2. Ability to create stock based on current geometry as well as using color filters has been implemented.

What's New in RhinoCAM 2021

POST PROCESSOR ENHANCEMENTS

1. A new programmable post-processor has been introduced. This module is a major enhancement to the post processor engine. Users can use the Python programming language to create posts.

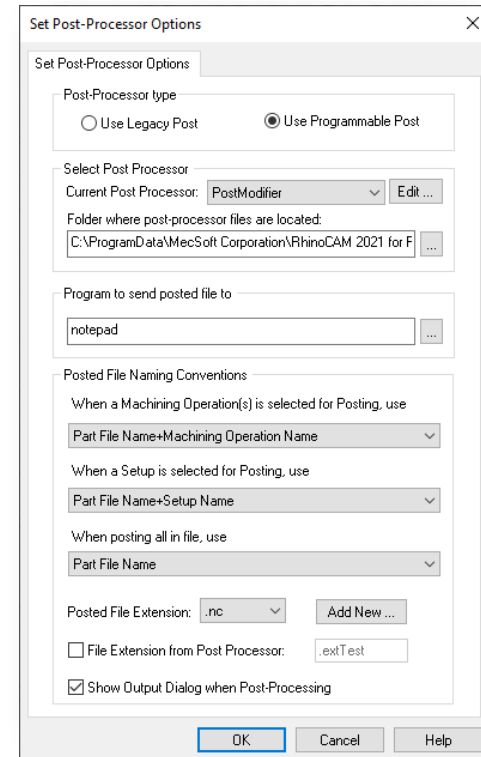

2. Post file extension definition can now be selected from the spm file in the case of the legacy post processor
3. The ability to output macros for Work Zero Offset was implemented for the legacy post processor

WHAT'S NEW IN THE TURN MODULE

1. All ID operations now retract the tool back along the rotational axis to clear the face of the part to prevent gouging of the part when an OD operation is followed by an ID operation.

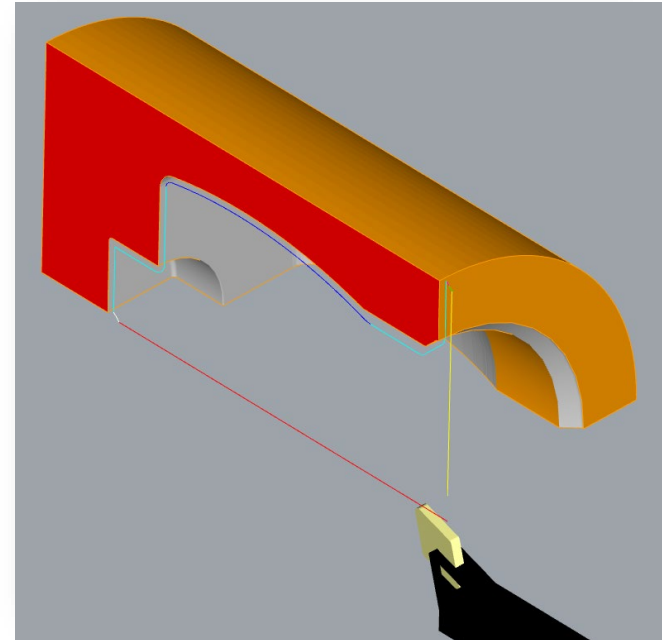

2. Arc fitting in all Turn toolpath methods has been implemented

WHAT'S NEW IN THE G-CODE EDITOR MODULE

1. The G-code editor display toolbar was introduced with the following functions:
 - Hide/show part visibility button to toggle display of part in Simulate tab
 - Hide/show toolpath visibility button to toggle display of stock in Simulate tab
 - Display of the G-code by Z levels



2. Allow cut material simulation by Z levels if the G-code was created using multiple Z levels
3. Find and Replace commands were implemented
4. Stock from selection was implemented

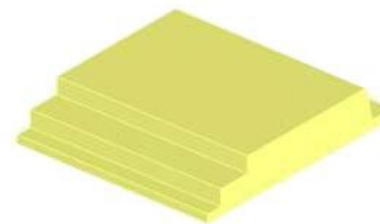

3D Geometry Selection for Stock

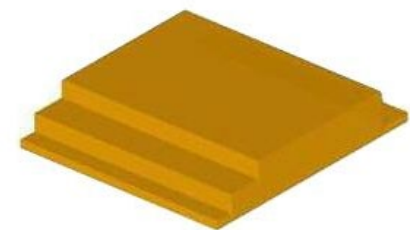

Stock Created from 3D Geometry

What's New in RhinoCAM 2021

5. Follow, Trace and Segment G-code display modes were introduced to enable better visibility of the G-code statements during simulation.

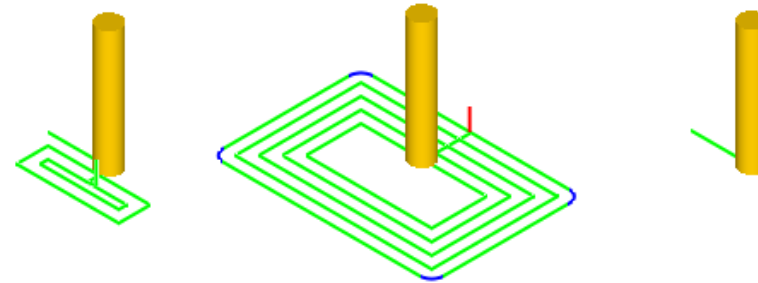

6. Additional file extension for G-code file types were added

WHAT'S NEW IN THE PROFILE-NEST MODULE

1. Allow renaming of sheet names when using curves to define sheet Enhancement request
2. Added an option to choose between True Shape & Rectangular Nesting
3. The ability to update length, width and bottom-left corner position for user defined sheets for Sheet selection dialog was added

WHAT'S NEW IN THE NEST MODULE

1. Moving every sheet's lower corner to the origin point on export was implemented.
2. When using explode cabinet design, provide an option to orient the longest edge of the parts along X or along Y
3. The ability to update length, width and bottom-left corner position for user defined sheets for Sheet selection dialog was added

In addition to this, multiple customer reported bugs were fixed in the NEST module.

WHAT'S NEW IN THE ART MODULE

No major enhancements were introduced in the ART module. Selected user reported bug-fixes were implemented.

WHAT'S NEW IN THE MESH MODULE

What's New in RhinoCAM 2021

New Machinework's Polygonica libraries were integrated to implement additional robustness and improved performance within most mesh functions.

BUGS FIXED

Numerous bugs have been fixed to make the product more reliable and robust.

1. Skim clearance is not honored in drilling when objects not participating as control geometry is locked in Rhino
2. Issues with load from file dialog for feeds/speeds in TURN module
3. In G-Code Editor module, brackets "" cause the toolpath to not display and to pause during simulations
4. Bug in Rotate, Mirror & Scale tabs in Transform dialog in G-code Editor module was fixed
5. Simulating a Setup with a Machining Operation Set that does not have any operations inside the mop set results in a serious unhandled error
6. RMB and rename under tools tab in Objects browser does not make the text editable
7. Simulating a mop inside a mop set does not show in-process stock from the mop set above it
8. In AFM Drilling, drill depth override field is missing in both 2019 and 2021, was present in 2017
9. Images from bug FN-759 "2021 Dialog Icon Enhancements" were implemented
10. Arcs are flipped when face edge is selected as drive region in AlibreCAM for attached test case
11. Toolpath Min Z and Max Z variables output the coordinate values in WCS when the coordinate system is in a different orientation
12. G-Code Editor module - Clipping plane issue with cut material simulation
13. G-Code Editor Module: Issues with simulating multiple g-code files
14. G-Code Editor Module: Simulation fails after g-code has been simulated, deleted and loaded back
15. G-Code Editor Module - Arcs in XZ and YZ planes are displayed as strange motions
16. G-Code Editor Module - Text appears very small on a high resolution monitor
17. Library Open Failure Error that happened in some cases in the licensing module was fixed
18. Filleting operation gouges part region when max depth/cut value set is less than corner radius
19. Spiral cut pattern with Horizontal Roughing ignores the engage/retract settings and does a plunge for the engagement
20. Drill operation outputs spindle speed mode as CSS (G96) instead of CRS (G97) when programmed after a TURN operation
21. Performing Block Edit command in Rhino & closing the dialog results in a serious unhandled error in RhinoCAM
22. Toolpath is offset away from part region when tool name is over 60 characters in length
23. Path Ramp fails to apply in 2 axis roughing when using spiral cut pattern for cavity regions
24. Setting Start point to inside in pocketing does not start on the inside when Always keep tool down is selected
25. Issues with High Speed Cut pattern in 3 axis horizontal roughing - toolpath gouges part geometry
26. Manipulator triad display is left behind even when no geometries are selected

What's New in RhinoCAM 2021

- 27. Memory leaks issues were fixed in core methods that are used for the Feature Detection
- 28. Generating chamfer operation for hole feature, results in incorrect toolpath
- 29. Surface and Fixture colors options do not apply to TURN module" was fixed.
- 30. Issue "If stock edge display is disabled, then the stock edge colors should also be disabled" was fixed.

Numerous other smaller bugs and under the hood changes were made.