

BILL BANCROFT

furniture design

Bill Bancroft is the owner/operator of [Bill Bancroft Furniture Design](#) located in Essex MA. Bill graduated from [Brown University](#) and obtained his master's degree in Furniture Design from the [Rhode Island School of Design](#). Bill's furniture designs have been shown in galleries across New England! Bill is also Adjunct Professor at [Wentworth Institute of Technology](#) (WIT) where he teaches materials classes and a furniture design studio. Bill has been using MecSoft CAM software since 2008, first with VisualMILL and now with RhinoCAM!

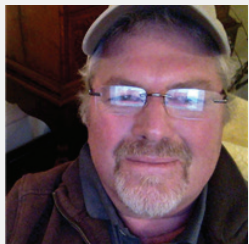
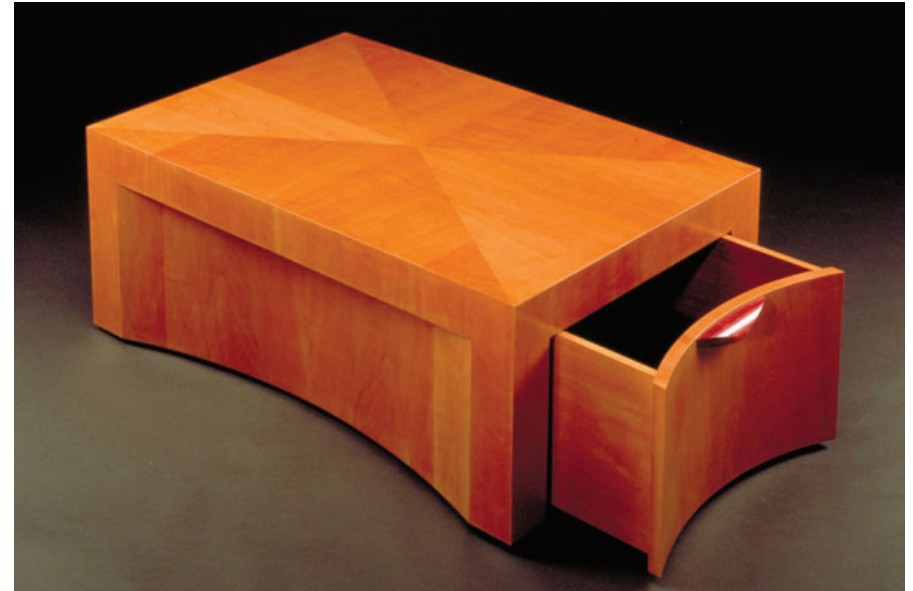

“RhinoCAM gets me to the end result I’m looking for with the minimum amount of hassle! Having toolpaths saved with the Rhino CAD file and the ability to easily reuse toolpath knowledge are two of the biggest time saving features that come to mind!”

Bill Bancroft, Owner/Operator, Bill Bancroft Furniture Design & Adjunct Professor, Wentworth Institute of Technology

When we recently sat down with Bill to discuss the use of RhinoCAM at his Essex MA shop, he wanted to take the opportunity to give some exposure to an up and coming furniture designer named Emma Schmidt. Emma is currently studying furniture design and has spent the last 6 months as an intern at Bill Bancroft Furniture Design. Emma, you're learning from the best and this case study is dedicated to you - great work!

The Designer

Emma Schmidt has a passion for furniture design and hopes to one day launch her own business! Hailing from Alexandria Virginia, Emma is currently a junior at the [Wentworth Institute of Technology](#) (Essex MA) majoring in Industrial Design and minoring in Entrepreneurial Business. While working as an intern at Bill Bancroft Furniture

Design, Emma was encouraged to design, 3D model, CAM, cut and assemble her own unique furniture design project. To this end, Emma designed and manufactured the unique furniture piece showcased below.

With RhinoCAM and students like Emma, we can rest assured that the future of furniture design is in good hands!



“As opposed to other CAM software that I have been exposed to, I find that RhinoCAM makes it very easy to evaluate my tool paths once the coding has been applied to a CAD drawing. I can easily spot concerns that need to be dealt with before heading to the CNC! RhinoCAM is great for that!”

Emma Schmidt, Student of Industrial Design, Wentworth Institute of Technology

The Design

Emma's design is of the classic [Memphis-Milano design style](#) that appeared briefly in the early part of the 1980s and whose signature design characteristics were bright colors, simple geometries and a post modernistic style. Emma first sketched the design by hand and then modeled it in Rhino based on orphan pieces of wood that the shop had on hand. The curved panel is a 3" stack lamination of 3/4" baltic birch plywood, the top desk pieces and wheel are solid walnut. The pieces are made with ready to assemble connectors, so she can take it apart and move it around. It's a very fun and unusual design!

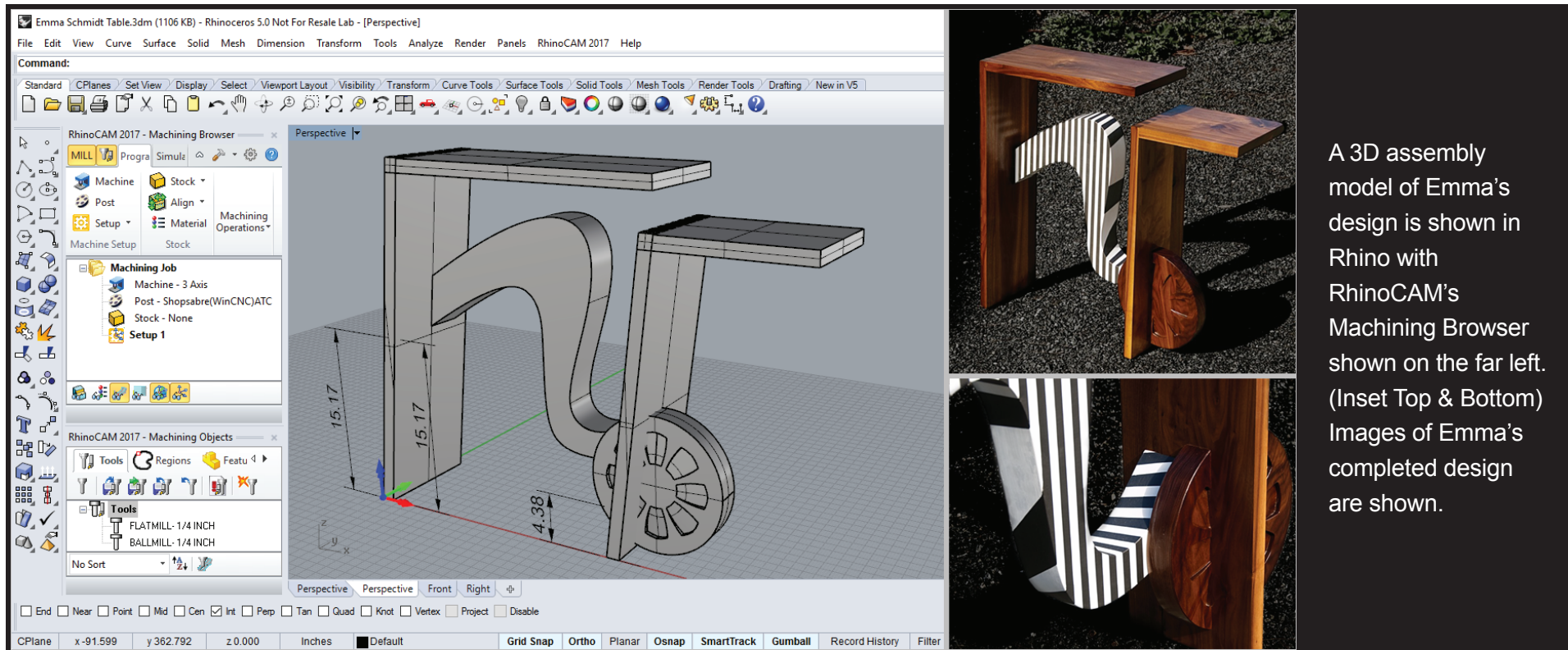

A 3D assembly model of Emma's design is shown in Rhino with RhinoCAM's Machining Browser shown on the far left. (Inset Top & Bottom) Images of Emma's completed design are shown.

The RhinoCAM Toolpaths

Let's have a look at the toolpaths that Emma has chosen to cut her furniture design components:

The Wheel

The wheel design encompasses both 2½ and 3 Axis toolpaths. For the daisy-chain pattern of contoured pockets, Emma chose the 3 Axis Horizontal Finishing operation using a ¼" Flat Mill with the stepdown set to 5% (0.0125"). Notice that the only geometry selected is a 9.7" diameter planer circle. Also known as Z-Level Finishing, the operation calculates the Z depths required within the containment area while compensating for the tool diameter.

The next operation is 2½ Axis Pocketing using a ⅜" Flat Mill. This is used to separate the wheel into the two parts her design requires. Notice that the only geometry needed here is a planar rectangle measuring 1.14"x 11.89". The pocketing operation cuts within the containment area at a total depth of 1.5" set to 10 levels of 0.15" each with an initial 10-degree ramp entry motion.

The remaining 2½ Axis Profiling operation uses the same ⅜" tool and cuts the outer perimeter at 0.2" cut levels. The part and toolpaths are shown below.

Watch the video of this part being cut:

<https://youtu.be/kyybNk7HZ6w>



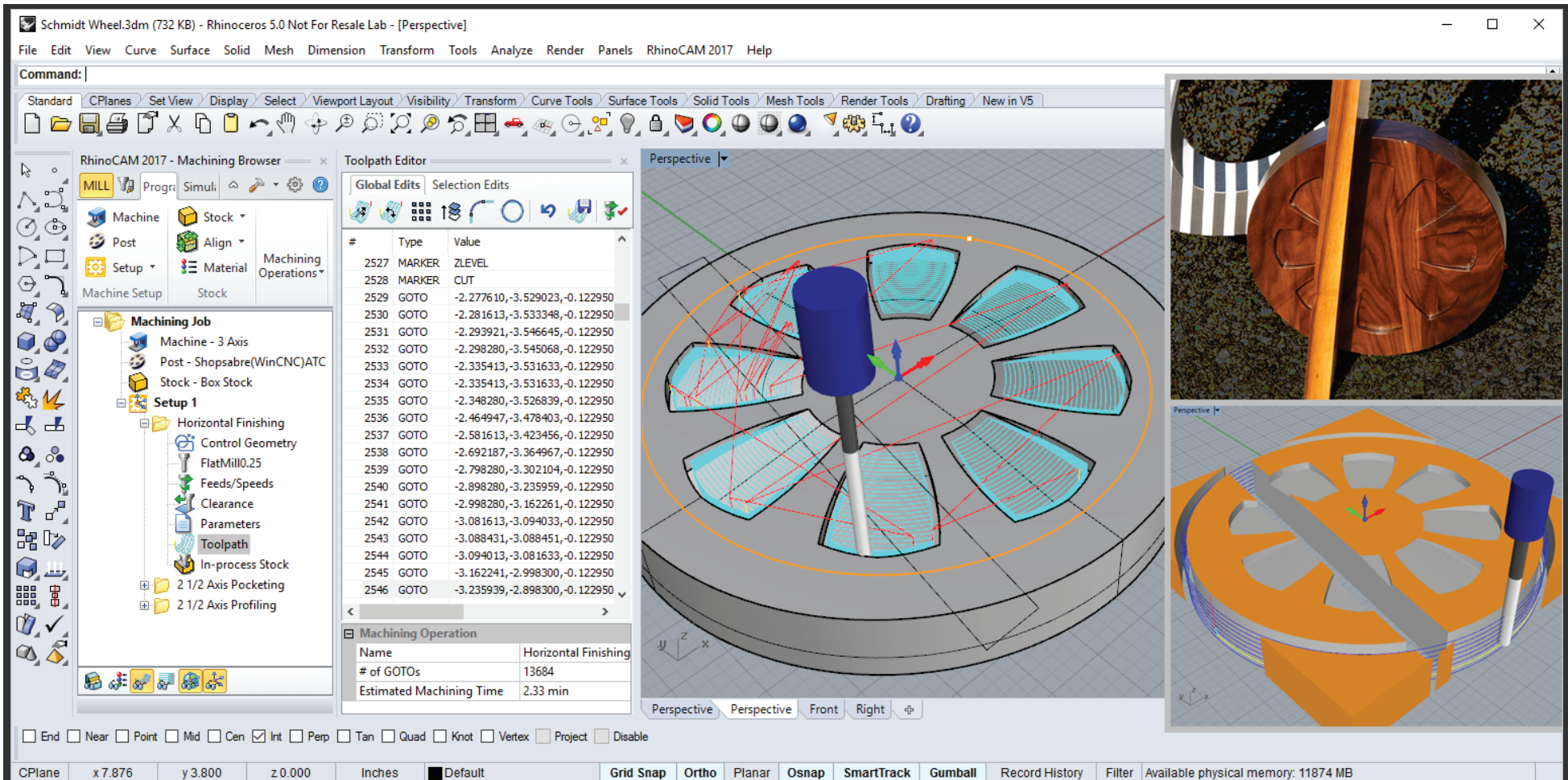

The 3D model of the wheel component is shown in Rhino with the RhinoCAM toolpaths that were used to cut the part. From left to right we see the RhinoCAM Machining Browser, the Toolpath Viewer/Editor and the display of a 3 Axis Horizontal Finishing operation. (Inset Bottom) The completed cut material simulation showing the tool cutting the 2½ Axis Profiling operation. (Inset Top) The completed design showing the wheel component in place.

The Stretcher

The Stretcher is the panel that connects the two vertical walls of the desk. It runs from mid-height on the left to the base on the right, just behind the wheel. For this Emma is cutting four stretcher components from 3/4" Baltic Birch plywood that will be laminated together to form the completed component. Also included in this operation are four Glue Supports used during assembly.

The 48"x48" stock for this operation is displayed in RhinoCAM below. We see that Emma is using a 2½ Axis Profiling operation with a 3/4" Flat Mill. For Control Geometry, only 2D closed curves lying on the XY Plane (at the top of the stock definition) are needed. The cut will be completed in three levels of 0.225" each. If you look closely you can see that Emma had enabled the automatic placement of Bridges/Tabs from the Advanced Cut Parameters tab of the Profiling operation dialog. Each closed profile will contain a total of six (6) triangular tabs

measuring 0.2" wide and 0.1" tall. These tabs will serve to help stabilize the part and stock during machining. The Bridges/Tabs section of the Cut Parameters tab is also shown below.

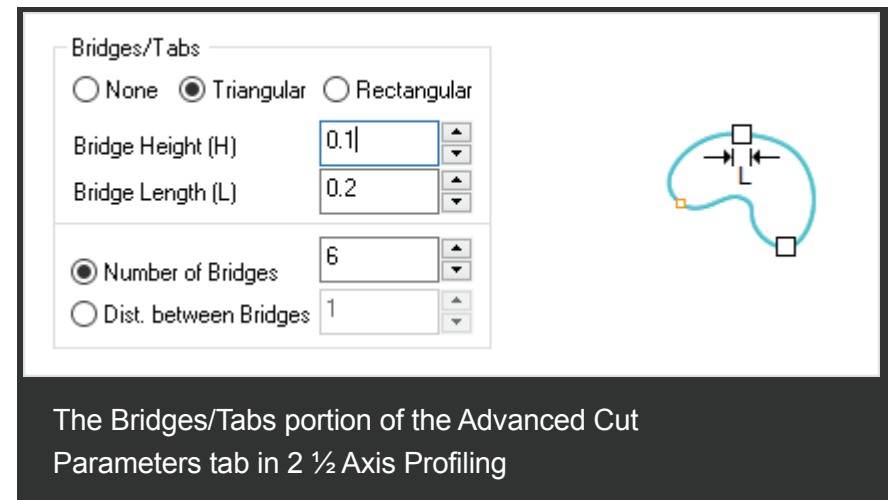

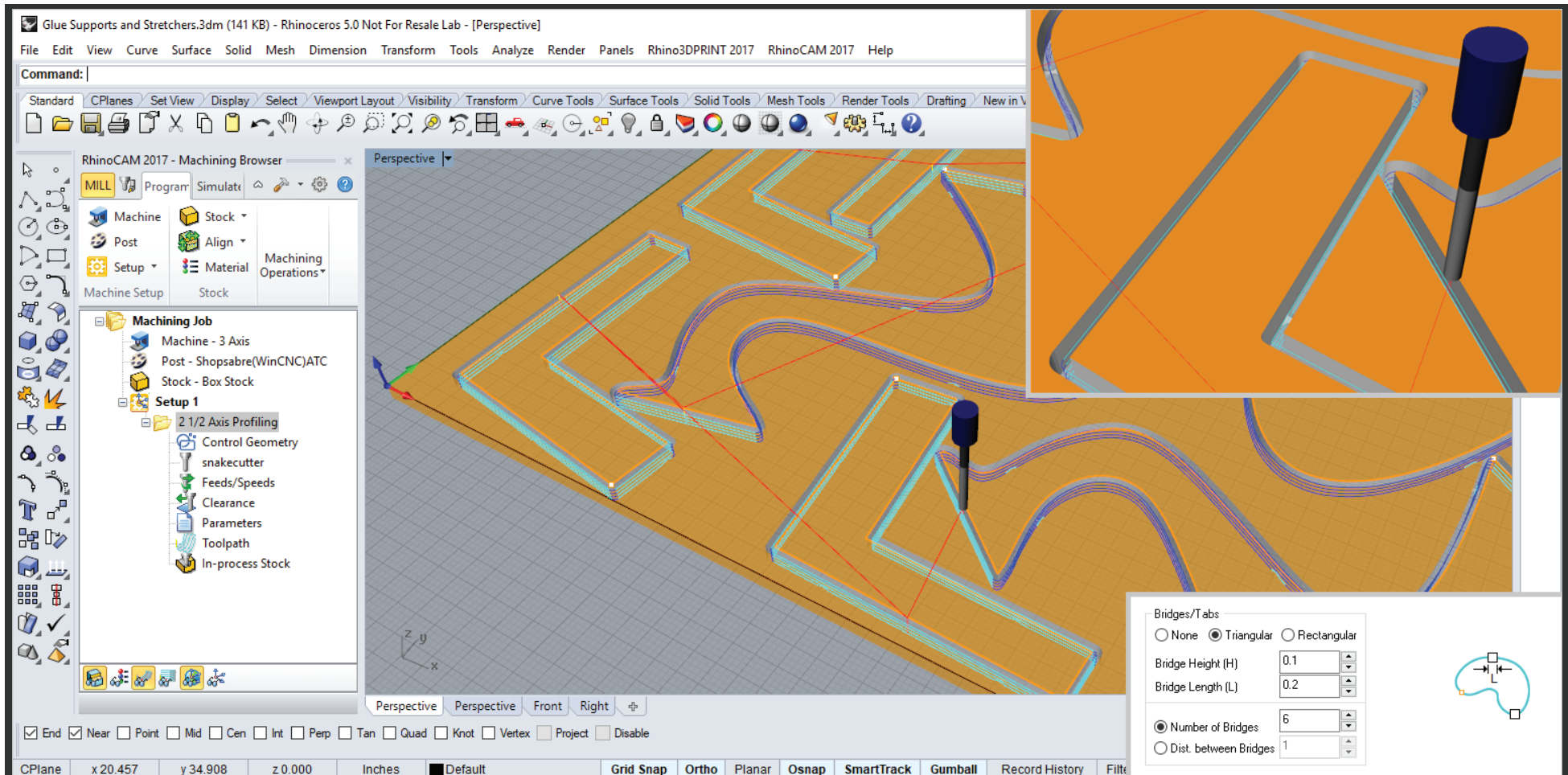

The 2D curve geometry representing the layout of glue supports and stretcher laminate components are shown in Rhino with the 2½ Axis Profiling toolpath created in RhinoCAM. (Inset Top) RhinoCAM cut material simulation showing the automatic placement of Bridges & Tabs (Inset Bottom) The Bridges & Tabs section of the 2 ½ Axis Profiling Advanced Cut Parameters tab shows the Bridges & Tabs parameters for the job.

The Finger Joints

In Emma's design, Finger Joints are used to attach the two horizontal components to their vertical counterparts. What's interesting here are the angles required. The vertical components are each 98 degrees from horizontal, making the finger joints more complex than usual. For this Emma again chose the 3 Axis Horizontal Finishing toolpath, this time using a ¼" Flat Mill set to a 20% stepdown distance.

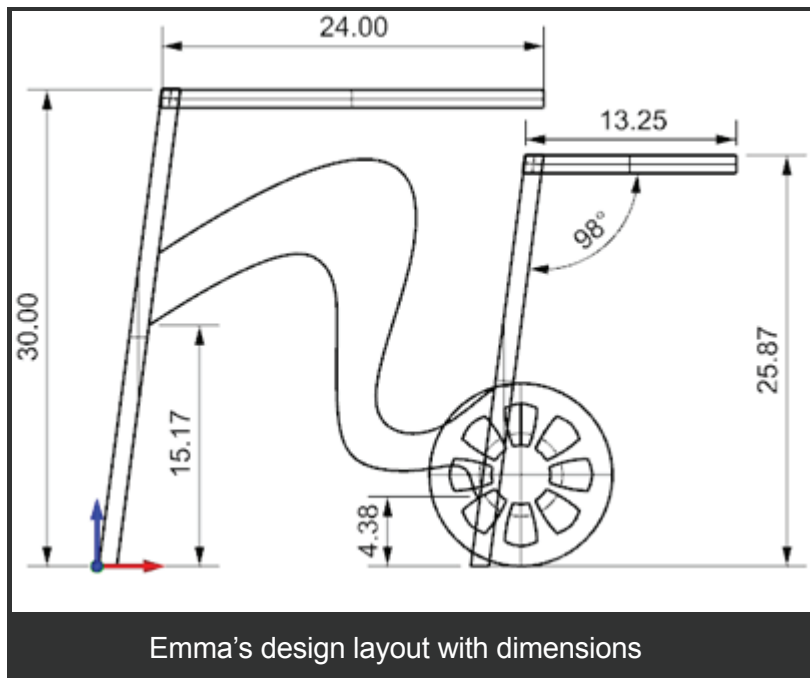

The Finger Joint components, toolpath, cut material simulation and final product are all shown below. Notice that only a simple planar rectangle (shown in the top-left image) is needed to contain the 3 Axis Horizontal Finishing toolpath to the required area. Great Job Emma!

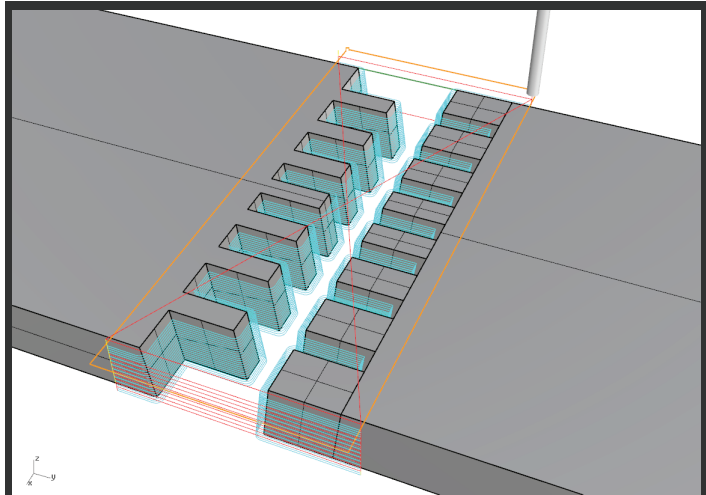

3 Axis Horizontal Finishing Toolpath of Finger Joint

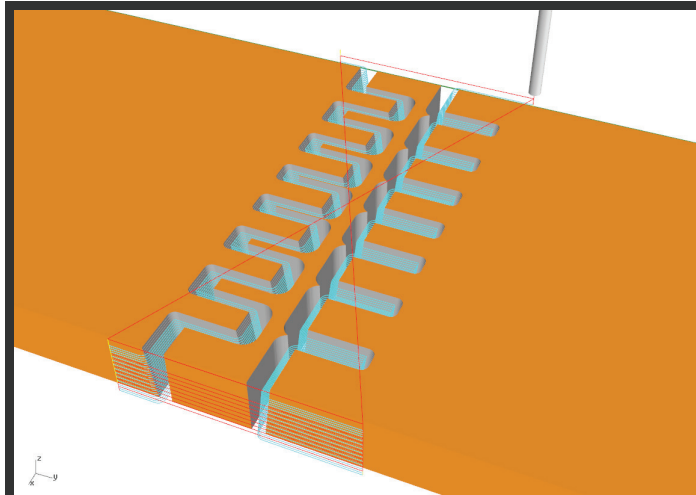

Cut Material Simulation

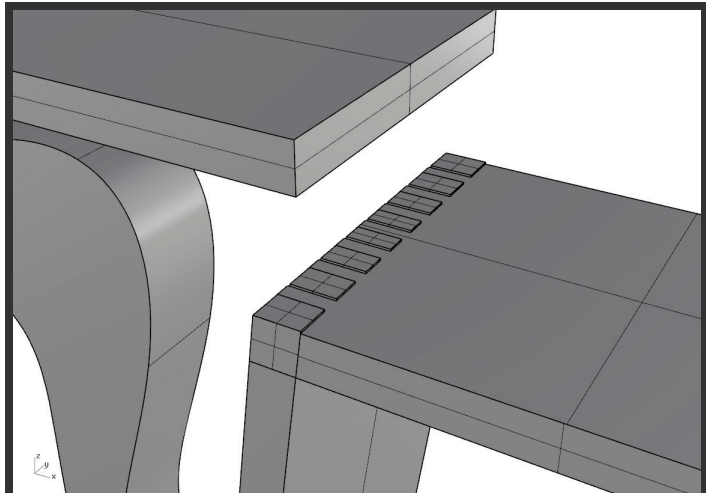

Finger Joint Assembly in Rhino



Finger Joints in Emma's Completed Design

We want to thank Bill Bancroft and Emma Schmidt for allowing us to showcase their work!

More about RhinoCAM from Emma Schmidt

“At first glance, it seemed super complicated and confusing. But after watching Bill go through the coding process, setting up the CNC and then watching the piece being cut on the table, it was easier for me to understand just what the software could do! Then, I understood why certain steps were necessary and which settings needed to be applied and when. After 3 months now of working with RhinoCAM, I feel very confident in using it!”

More about Bill Bancroft Furniture Design

In addition to gallery furniture design, [Bill Bancroft Furniture Design](#) also offers custom made to order furniture, architectural millwork, custom cabinetry, prototyping, CNC milling, consulting and more! Here are just a few of Bill's designs:



More about RhinoCAM

RhinoCAM is available in 5 different configurations (Express, Standard, Expert, Professional and Premium). The part shown here was programmed using the Professional configuration. Here are some additional details about each of the available configurations. [Click here for the complete features list.](#)

- **RhinoCAM Express:** This is a general-purpose program tailored for hobbyists, makers and students. Ideal for getting started with CAM programming. Includes 2 & 3 axis machining methods
- **RhinoCAM Expert:** Includes the Standard configuration plus 4 Axis machining strategies, advanced cut material simulation and tool holder collision detection.
- **RhinoCAM Premium:** Includes the Standard, Expert and Professional configurations plus 5 Axis simultaneous machining strategies.
- **RhinoCAM Standard:** This is a general-purpose machining program targeted at the general machinist. This product is ideal for the rapid-prototyping, hobby and educational markets where ease of use is a paramount requirement. Includes 2-1/2 Axis, 3 Axis and Drilling machining methods.
- **RhinoCAM Professional:** Includes the Standard and Expert configuration plus advanced 3 Axis machining strategies, 5 Axis indexed machining, machine tool simulation, graphical toolpath editing and a host of other features.

To read more about RhinoCAM and other MecSoft Corporation products including screen images, resources and features lists, please visit our [Product page](#). You can also [demo our products](#) to take them for a test drive.